

Lift Truck & Materials Handling Edition

# ivt

INTERNATIONAL 2003  
INDUSTRIAL VEHICLE TECHNOLOGY

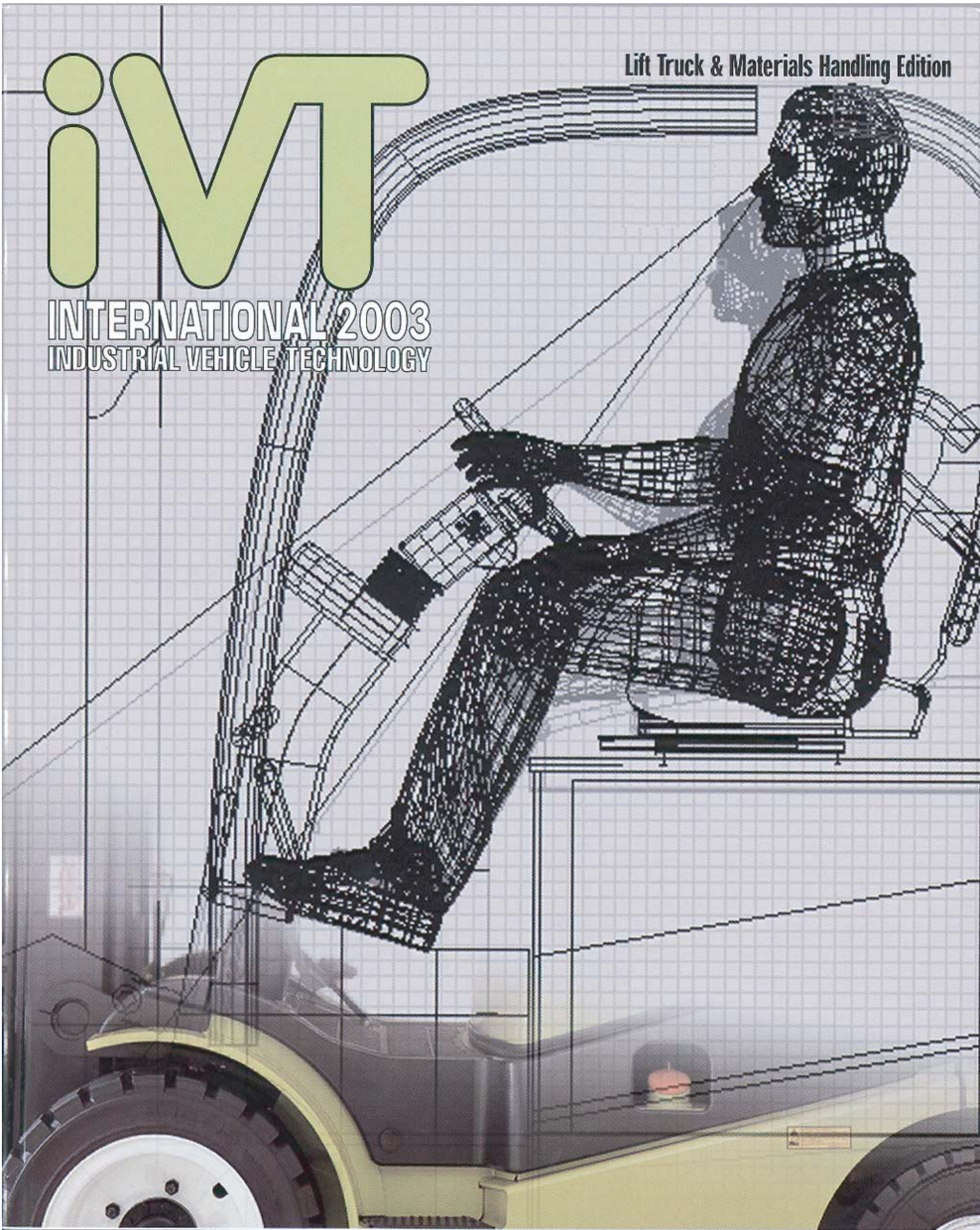

# LEAKING INFORMATION



Keep this to yourself, but the use of Hydraulic Integrated Circuits can help to dramatically reduce oil leaks. Here's the lowdown from someone on the inside...

**W**hether you like it or not, the use of hydraulics has become synonymous with oil leaks. In the past, the best sealing and fitting technology has not been universally applied and in some applications, even the best practice has not been able to eliminate the problem. Some companies have even abandoned the use of oil hydraulics altogether in favour of 'cleaner' power transmitters such as water hydraulics, or electrical and pneumatic systems, even though these technologies have not otherwise been ideal. Indeed, it has been estimated that up to 70% of oil leaks come from tube/hose fittings or their interface with other components such as valves, pumps and actuators.

While it is recognised that great strides have been made in sealing technology, fitting design and in pipe work design, cutting out potential leak paths has to be the best solution to oil leaks, and this – the most practical solution – can in most cases save money as well.

As hydraulic systems become more sophisticated and therefore use more control elements, the number of connections between valves and pipe work inevitably increases. But the use of Hydraulic Integrated Circuits (HIC) or manifold systems can go a long way towards reducing the number of external connections required in a system.

With the advent of cartridge technology, complete control circuits can be contained within one piece of aluminium, steel or cast iron. Twenty or more control elements can be designed to fit together with only internal galleries making connection between each cartridge. This keeps the number of potential leak paths to a minimum, removing the need for an assortment of tubes, hoses and fittings.

Of course, it may not always be practical to put all valves into one HIC, but even the simplest of circuits can be made much cleaner. Most cartridge valves in themselves have at least two potential leak paths, the cartridge/HIC joint and the adjuster/cartridge joint

but these can be designed to be entirely leak-free. In ideal circumstances they are assembled by technicians trained to do that specific task, with good access and all the appropriate tools to hand. Also, when a valve is vented, using those with an internal vent, such as Integrated Hydraulics' internally vented motion-control cartridges, will reduce the number of possible leak paths. A further aid to reducing leak paths is the use of multifunction cartridges, whereby one cartridge can take the place of two or more.



Example of Hydraulic Integrated Circuit

Even though the probability of a cartridge and block leaking is minimal, multifunction cartridges will reduce it further and they will also reduce the size, weight and possibly the complexity of the block in which they fit.

As an example of the HIC approach, take a simple circuit designed to enable an operator to manually select one of three pressure settings in a clamp circuit (Figure 1). The cartridge used is a typical example of a relief valve that fits into a specially machined cavity (Figure 2). An O-Ring and back-up ring separate the inlet from the tank port, eliminating internal leakage. The joint between the cartridge and the HIC is sealed with another O-Ring in the style of an SAE O-Ring port and the seal on the adjuster is another O-Ring with back-up ring. The cavity is machined to suit the cartridge so the extrusion gap between its nose and the block is tightly controlled; the cartridge is tightened down to give a zero extrusion gap at the face of the block and the seal of the adjuster is controlled by the tolerance and surface finish of the bore in which it runs.

From the drawings it can be seen that to line-mount these valves would involve at least 10 fittings, 33 leak paths and

some accurate pipe bending (Figure 3) whereas the HIC has only two fittings (four leak paths). The space needed is also dramatically reduced (Figure 4).

Some people shy away from this sort of solution for a number of reasons, which, on closer inspection are generally groundless if the cartridges and the HIC are designed and manufactured to an acceptable standard. Resistance to the use of hydraulic integrated circuits can be summed up under cost, difficulty in troubleshooting, performance worries and mounting restrictions.

#### The cost factor

HICs can only economically be produced in quantities – one-off applications are usually better served using Cetop standard interfaces and stacking valve systems. With modern flexible machining centres, manifold blocks can be cost-effective in quantities as low as 25. Even though the initial outlay in time and tooling may seem high, the amount saved by eliminating expensive pipes and fittings, along with reduced installation time and the possible elimination of oil leaks, makes this technology much more attractive. Cost savings and product improvements can also be

achieved in the development stages as cartridge valves can be changed easily and manifolds modified to achieve optimum performance. Additionally, Integrated Hydraulics has a wide standard range and an impressive R&D department to provide practically any required hydraulic function, ensuring the homogeneity of the complete control system. Cartridge valves are themselves generally more economical to make than conventional control valves, so machine performance can often be improved through realising greater functionality for the same price as alternative methods.

#### Troubleshooting

Any HIC can be designed with as many test points as required while all the cartridges in a block should be able to be extracted without removing the block from the machine, and therefore without disturbing the pipework. With traditional line-mounted valves it is not unusual to have to remove surrounding pipework before a failed valve can be freed. This ability to change a cartridge quickly cuts downtime sufficiently to warrant the use of new cartridges rather than servicing the old ones. Due to their

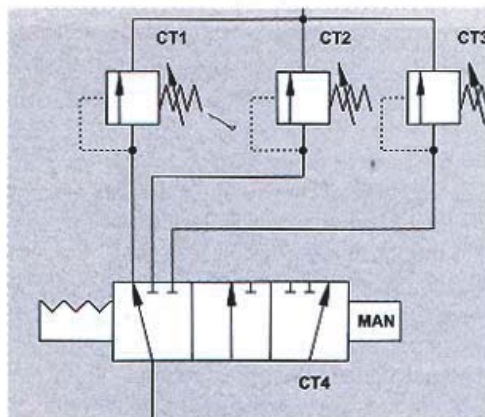

FIGURE 1: Manually selected three pressure relief circuit

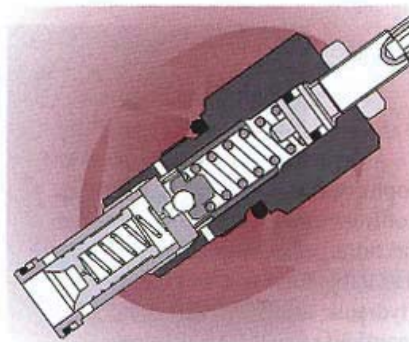

FIGURE 2: The 1AR100 pilot-operated, sliding spool-type relief cartridge

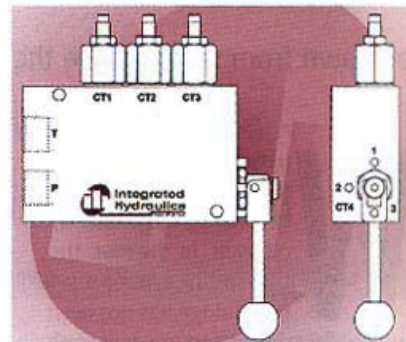

FIGURE 4: Hydraulic Integrated Circuit

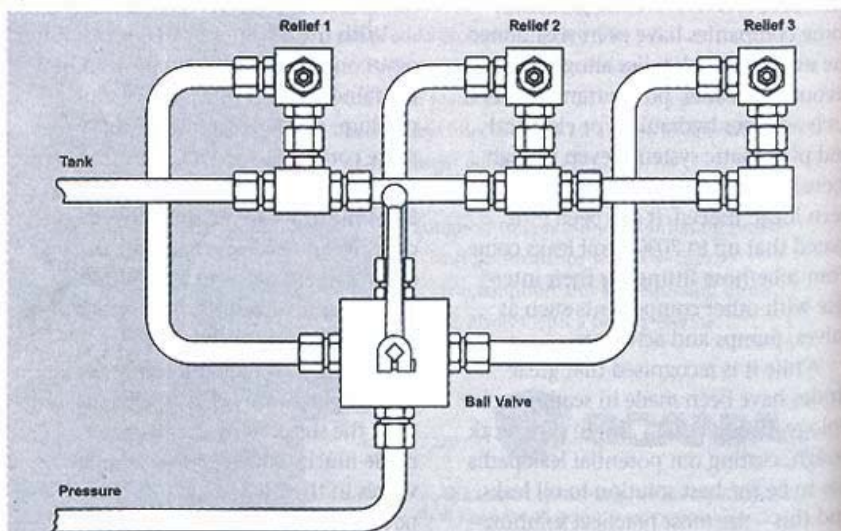

FIGURE 3: Line-mounted circuit

low cost, should a cartridge valve fail or be damaged, it is inexpensive to change. As an example, you wouldn't think twice about throwing away spark plugs if a car failed to start. Only the failure of the block itself would present the engineer with any real problem. This, however, is a rare occurrence because a well-designed manifold housing will have more than enough strength to cope with the hydraulic stresses imposed upon it. And the use of cartridge valves in the block ensure that there are no moving parts bearing on the block itself – so no wear.

### Performance

Unfavourable flow paths and sharp corners are cited as reasons to expect poor performance from an HIC. However, experience leads us to believe that the performance of integrated circuits is often better than an equivalent traditionally piped system. While bent tube gives good flow conditions, most tube fittings introduce a change-in-bore area which is detrimental to flow. Additionally, elbows and tee fittings usually exhibit the same flow restrictions as drillings in a manifold. Indeed, Integrated Hydraulics designs manifold

blocks so that the galleries between each element tend to be larger than the nominal bore of a steel pipe or a flexible hose assembly in an equivalent system using in-line valves.

### Mounting restrictions

It is true that an HIC system will be less flexible than in-line valves once the block is in production. So, to achieve the undoubted benefits of such systems, comprehensive initial design is essential. An HIC should be designed into the machine as a whole: if this is done, its use can simplify mounting. By strategically positioning the ports, etc, unnecessary elbows and bends can be eliminated. The relevant advantage in this case is the reduction of leak paths, reducing oil loss and creating a cleaner environment.

Integrated circuitry can be taken a step further by mounting the HIC directly on to the pump, motor or actuator. This can be done relatively easily as most manufacturers of these items provide a surface for flange fittings. These, though not always ideal, can be effective. By adopting this method, complete runs of pipe can be removed.

This obviously has a dramatic effect on the number of leak paths in

a system. It does, however, take some foresight on the part of the machine designer to make sure there is space around the prime part onto which he wishes to mount the valve.

Going a stage further, in some cases the cartridge valves could be mounted in the prime component. A hose rupture valve circuit could be produced in a cylinder's end caps, saving cost, weight and space. Alternatively, pressure reducing and flow controls could be incorporated in a hydraulic motor to provide a torque-limiting feature.

Integrated Hydraulics' screw-in cartridge valve technology enables the concentration of numerous hydraulic control functions into a single block, be it a single valve dictating the descent of a cylinder or an elaborate manifold controlling all the machine's operations. This can dramatically reduce the pipework required in a system which, in turn, can dramatically reduce the number of leak paths – where vibration and shock loadings work to produce oil leaks. **IVT**

✎ *Maurice Ashmore joined Integrated Hydraulics as a designer in 1978, taking on responsibility for the design and application of HIC's. He has sold cartridge valve systems in many industrial and geographic sectors*